

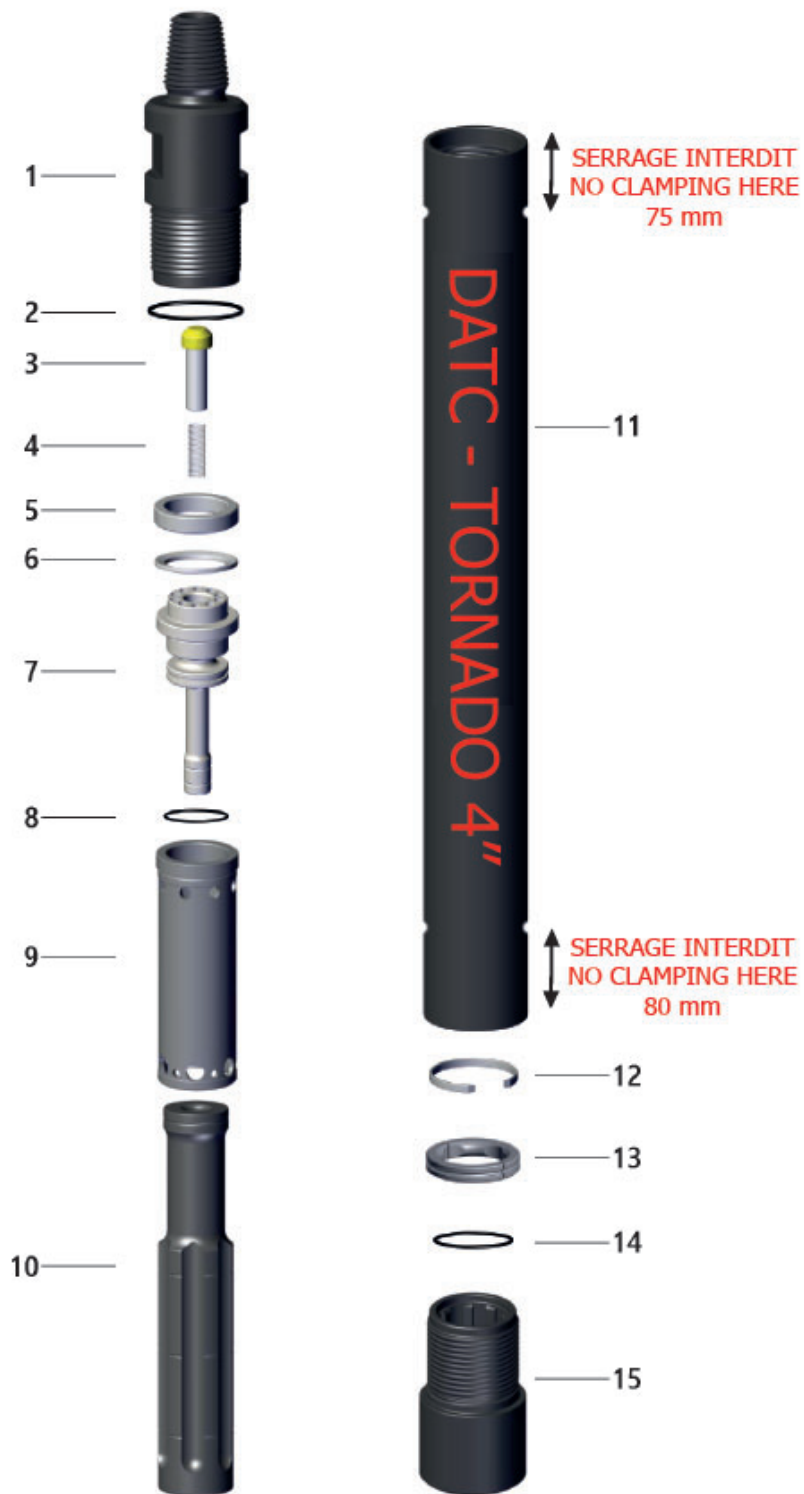

# FORAGE AU MARTEAU FOND DE TROU

## DOWN THE HOLE HAMMER DRILLING

### 4" TORNADO 4





# TORNADO 4 4"

### Caractéristiques du Marteau / Hammer Overview

Marteau / Hammer Type	TORNADO 4"
Numéro d'article / Part Number	DTHTG0400DHD34
Emmanchement / Shank	DHD 340
Filetage / Top Thread	2-3/8 API REG mâle
Poids / Weight	39.7 kg (87.5 lb)
Diamètre extérieur / Outside Diameter	98mm (3.9 inch)
Longueur / Make Up Length	961.1mm (37.8 inch)

### Liste de Pièces / Parts List

Type de marteau / Hammer Type		TORNADO 4"	
Numéro d'article / Part Number		DTHTG0400DHD34	Contents
N° / Item	Description	N° Art. / Part No.	Qté. / Qty
1	Raccord de tête 2-3/8 API Reg / Top Sub (API 2-3/8")	DTHTG04A-1-T	1
2	Joint torique de tête / Top Sub O Ring	DTHTG04A-1-TO	1
3	Clapet anti-retour / Check Valve	DTHTG04A-1-V	1
4	Ressort de valve anti-retour / Check Valve Spring	DTHTG04A-1-VS	1
5	Entretoise / Spacer Ring	DTHTG04A-1-HS	1
6	Rondelle Ressort / Disk Spring	DTHTG04A-1-HD	1
7	Distributeur d'air / Air Distributor	DTHTG04A-1-D	1
8	Joint torique distributeur air / Air Distributor O-ring	DTHTG04A-1-DO	1
9	Cylindre / Cylinder	DTHTG04A-1-L	1
10	Piston / Piston	DTHTG04A-D-P	1
11	Cylindre extérieur / Case	DTHTG04A-D-C	1
12	Anneau de retenue du piston / Stop Ring	DTHTG04A-1-S	1
13	Demies coquilles / Bit Retainer Ring	DTHTG04A-D-R	1
14	Joint torique demies coquilles / Bit Retainer Ring O Ring	DTHTG04A-D-RO	1
15	Porte outil / Drive Chuck	DTHTG04A-D-K	1

## Consommation d'air économique Economical Air Consumption

CFM m<sup>3</sup>/min

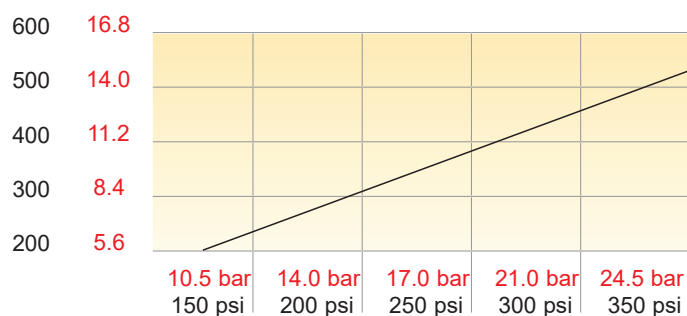



# 5" TORNADO 5

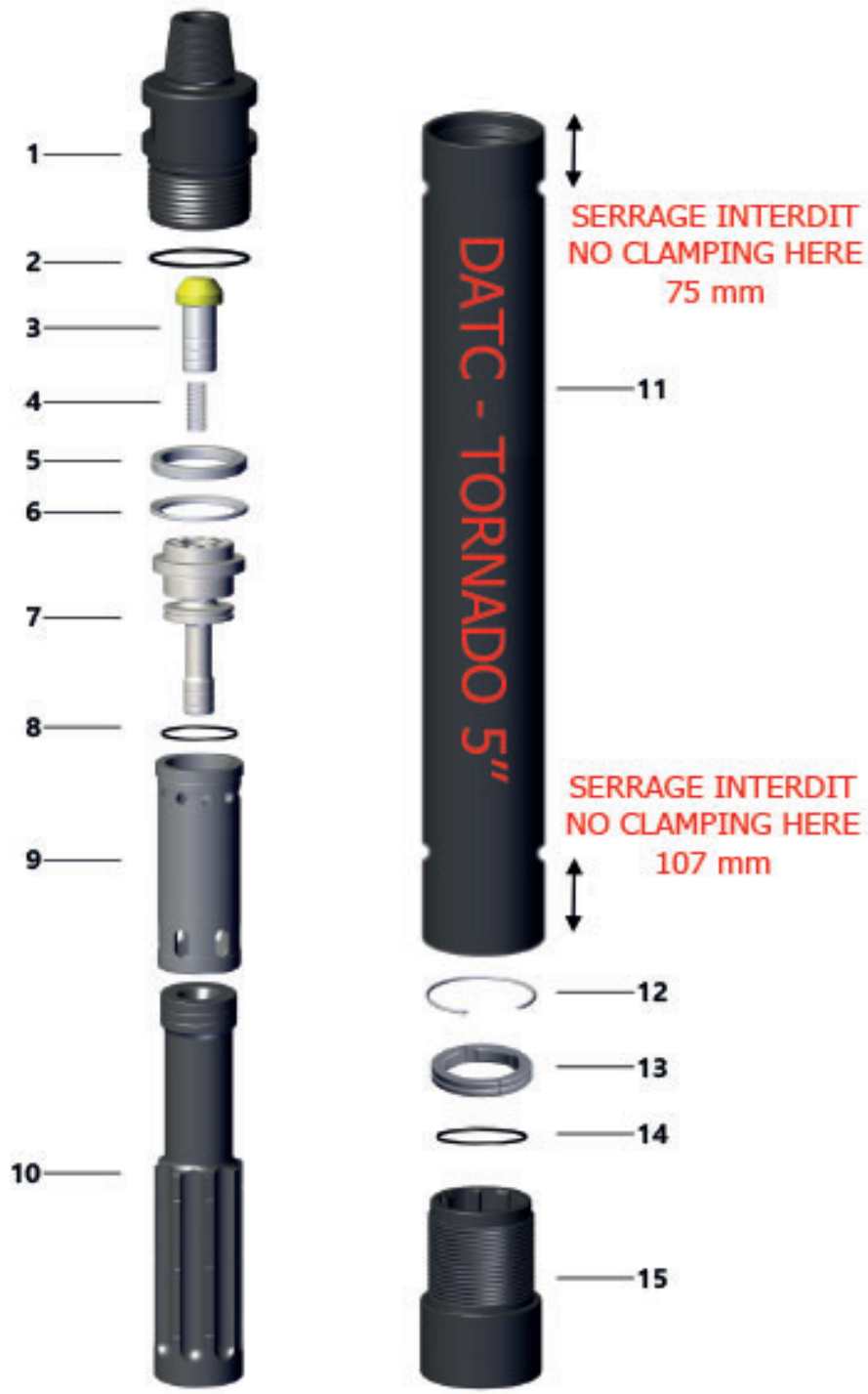



# TORNADO 5

# 5"

### Caractéristiques du Marteau / Hammer Overview

Marteau / Hammer Type	TORNADO 5"
Numéro d'article / Part Number	DTHTG0500DHD35
Emmanchement / Shank	DHD 350
Filetage / Top Thread	3-1/2 API REG mâle
Poids / Weight	61.5 kg (135.6 lb)
Diamètre extérieur / Outside Diameter	118mm (4.6 inch)
Longueur / Make Up Length	1081mm (42.6 inch)

### Liste de Pièces / Parts List

Type de marteau / Hammer Type		TORNADO 5"	
Numéro d'article / Part Number		DTHTG0500DHD35	Contents
N° / Item	Description	N° Art. / Part No.	Qté. / Qty
1	Raccord de tête 3-1/2 API Reg / Top Sub (API 3-1/2")	DTHTG05A-1-T	1
2	Joint torique de tête / Top Sub O Ring	DTHTG05A-1-TO	1
3	Clapet anti-retour / Check Valve	DTHTG05A-1-V	1
4	Ressort de valve anti-retour / Check Valve Spring	DTHTG05A-1-VS	1
5	Entretoise / Spacer Ring	DTHTG05A-1-HS	1
6	Rondelle Ressort / Disk Spring	DTHTG06A-1-HD	1
7	Distributeur d'air / Air Distributor	DTHTG05A-1-D	1
8	Joint torique distributeur air / Air Distributor O-ring	DTHTG05A-1-DO	1
9	Cylindre / Cylinder	DTHTG05A-1-L	1
10	Piston / Piston	DTHTG05A-D-P	1
11	Cylindre extérieur / Case	DTHTG05A-D-C	1
12	Anneau de retenue du piston / Stop Ring	DTHTG05A-1-S	1
13	Demies coquilles / Bit Retainer Ring	DTHTG05A-D-R	1
14	Joint torique demies coquilles / Bit Retainer Ring O Ring	DTHTG05A-D-RO	1
15	Porte outil / Drive Chuck	DTHTG05A-D-K	1

## Consommation d'air économique Economical Air Consumption

CFM m<sup>3</sup>/ min

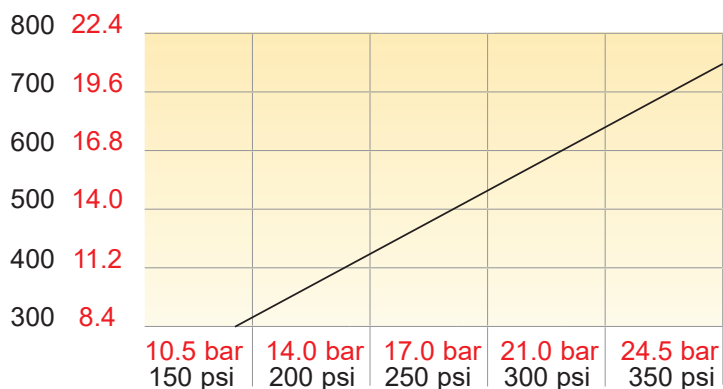



# 6" TORNADO 6

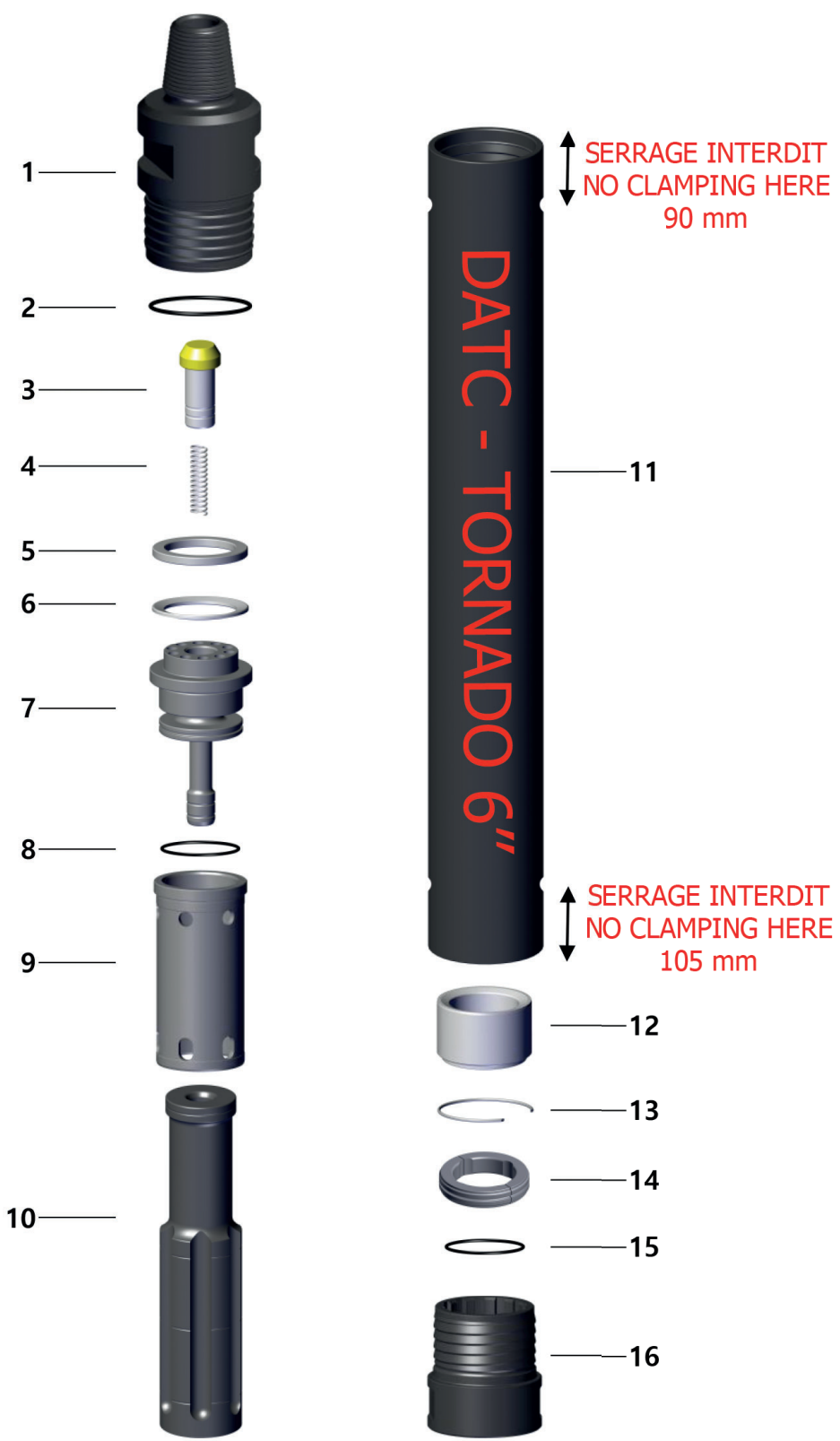



# TORNADO 6

# 6"

### Caractéristiques du Marteau / Hammer Overview

Marteau / Hammer Type	TORNADO 6"
Numéro d'article / Part Number	DTHTG0600DHD36
Emmanchement / Shank	DHD 360
Filetage / Top Thread	3-1/2 API REG mâle
Poids / Weight	104.2 kg (229.7 lb)
Diamètre extérieur / Outside Diameter	142mm (5.6 inch)
Longueur / Make Up Length	1218.5mm (48 inch)

### Liste de Pièces / Parts List

Type de marteau / Hammer Type		TORNADO 6"	
Numéro d'article / Part Number		DTHTG0600DHD36	Contents
N° / Item	Description	N° Art. / Part No.	Qté. / Qty
1	Raccord de tête 3-1/2API Reg / Top Sub (API 3-1/2")	DTHTG06A-1-T	1
2	Joint torique de tête / Top Sub O Ring	DTHTG06A-1-TO	1
3	Clapet anti-retour / Check Valve	DTHTG06A-1-V	1
4	Ressort de valve anti-retour / Check Valve Spring	DTHTG06A-1-VS	1
5	Entretoise supérieure / Spacer Ring	DTHTG06A-1-HS	1
6	Rondelle Ressort / Disk Spring	DTHTG06A-1-HD	1
7	Distributeur d'air / Air Distributor	DTHTG06A-1-D	1
8	Joint torique distributeur air / Air Distributor O-ring	DTHTG06A-1-DO	1
9	Cylindre / Cylinder	DTHTG06A-1-L	1
10	Piston / Piston	DTHTG06A-D-P	1
11	Cylindre extérieur / Case	DTHTG06A-D-C	1
12	Roulement / Bearing	DTHTG06A-D-B	1
13	Anneau de retenue du piston / Stop Ring	DTHTG06A-1-S	1
14	Demies coquilles / Bit Retainer Ring	DTHTG06A-D-R	1
15	Joint torique demies coquilles / Bit Retainer Ring O Ring	DTHTG06A-D-RO	1
16	Porte Outils / Drive Chuk	DTHTG06A-D-K	1

## Consommation d'air économique Economical Air Consumption

CFM m<sup>3</sup>/min

1100 31.1

1000 28.0

900 25.4

800 22.4

700 19.6

600 16.8

500 14.0

400 11.2

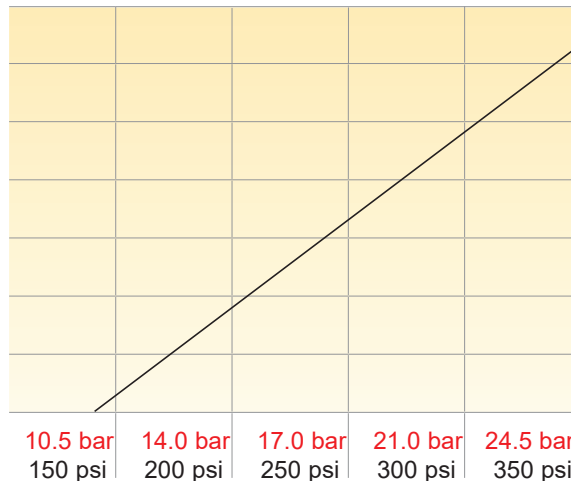

3



# FORAGE AU MARTEAU FOND DE TROU

## DOWN THE HOLE HAMMER DRILLING

# 8"

# TORNADO 8

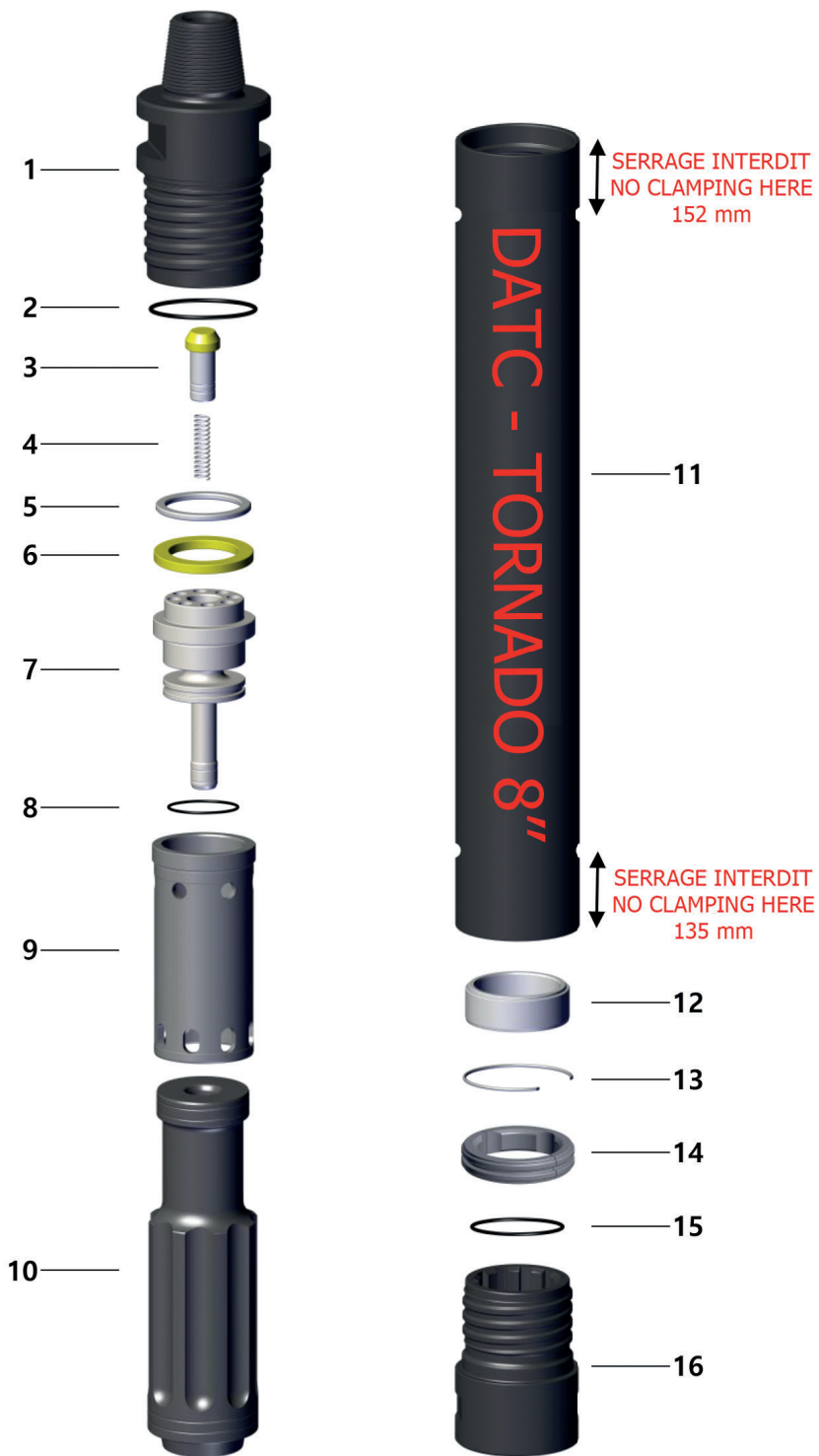



# TORNADO 8

# 8"

### Caractéristiques du Marteau / Hammer Overview

Marteau / Hammer Type	TORNADO 8"
Numéro d'article / Part Number	DTHTG0800DHD38
Emmanchement / Shank	DHD 380
Filetage / Top Thread	4-1/2 API REG mâle
Poids / Weight	195.5 kg (431.1 lb)
Diamètre extérieur / Outside Diameter	182mm (7.2 inch)
Longueur / Make Up Length	1400mm (55.1 inch)

### Liste de Pièces / Parts List

Type de marteau / Hammer Type		TORNADO 8"	
Numéro d'article / Part Number		DTHTG0800DHD38	Contents
N° / Item	Description	N° Art. / Part No.	Qté. / Qty
1	Raccord de tête 4-1/2" API Reg / Top Sub (API 4-1/2")	DTHTG08A-1-T	1
2	Joint torique de tête / Top Sub O Ring	DTHTG08A-1-TO	1
3	Clapet anti-retour / Check Valve	DTHTG08A-1-V	1
4	Ressort de valve anti-retour / Check Valve Spring	DTHTG08A-1-VS	1
5	Entretoise supérieure / Spacer Ring	DTHTG08A-1-HS	1
6	Entretoise inférieure / Make-up Ring	DTHTG08A-1-HM	1
7	Distributeur d'air / Air Distributor	DTHTG08A-1-D	1
8	Joint torique distributeur air / Air Distributor O-ring	DTHTG08A-1-DO	1
9	Cylindre / Cylinder	DTHTG08A-1-L	1
10	Piston / Piston	DTHTG08A-D-P	1
11	Cylindre extérieur / Case	DTHTG08A-D-C	1
12	Roulement / Bearing	DTHTG08A-D-B	1
13	Anneau de retenue du piston / Stop Ring	DTHTG08A-1-S	1
14	Demies coquilles / Bit Retainer Ring	DTHTG08A-D-R	1
15	Joint demies coquilles / Bit Retainer Ring O Ring	DTHTG08A-D-RO	1
16	Porte Outils / Drive Chuk	DTHTG08A-D-K	1

## Consommation d'air économique Economical Air Consumption

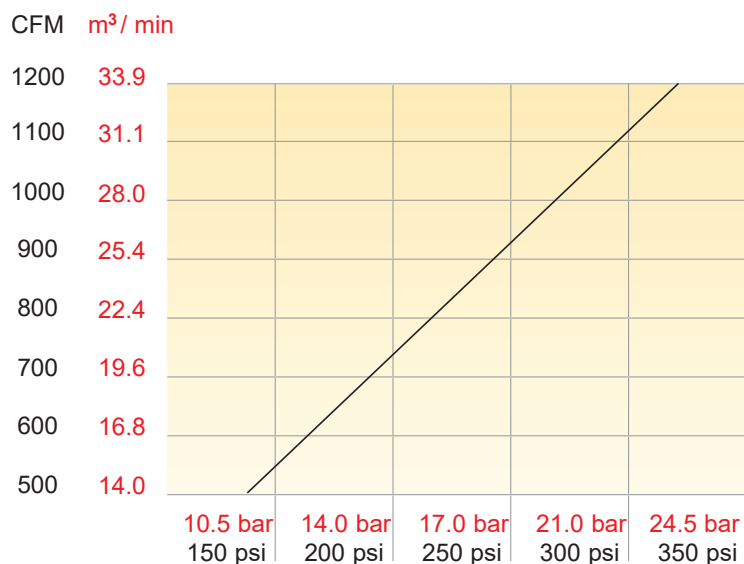





# 10" TORNADO 10

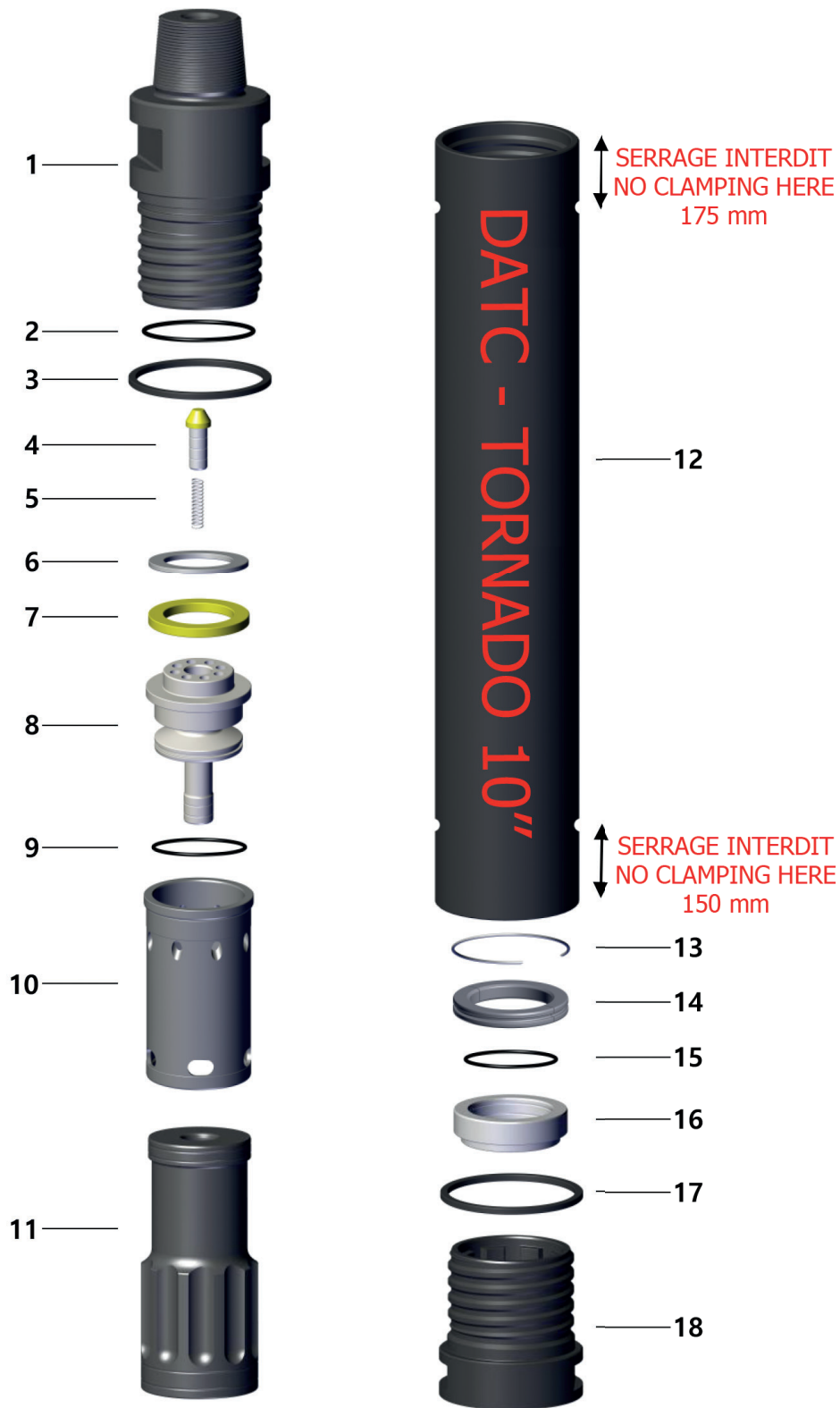



# TORNADO 10 10"

### Caractéristiques du Marteau / Hammer Overview

Marteau / Hammer Type	TORNADO 10"
Numéro d'article / Part Number	DTHTG100L0SD10
Emmanchement / Shank	SD10
Filetage / Top Thread	6-5/8 API REG mâle
Poids / Weight	310 kg (684.1 lb)
Diamètre extérieur / Outside Diameter	225mm (8.9 inch)
Longueur / Make Up Length	1387mm (54.6 inch)

### Liste de Pièces / Parts List

Type de marteau / Hammer Type		TORNADO 10"	
Numéro d'article / Part Number		DTHTG100L0SD10	Contents
N° / Item	Description	N° Art. / Part No.	Qté. / Qty
1	Raccord de tête 6-5/8API Reg / Top Sub (API 6-5/8")	DTHTG10A-1-T	1
2	Joint torique de tête / Top Sub O Ring	DTHTG10A-1-TO	1
3	Joint torique distributeur d'air / Top Sub Washer	DTHTG10A-1-W	1
4	Clapet anti-retour / Check Valve	DTHTG10A-1-V	1
5	Ressort de valve anti-retour / Check Valve Spring	DTHTG10A-1-VS	1
6	Entretoise supérieure / Spacer Ring	DTHTG10A-1-HS	1
7	Entretoise inférieure / Make-up Ring	DTHTG10A-1-HM	1
8	Distributeur d'air / Air Distributor	DTHTG10A-1-D	1
9	Joint torique distributeur air / Air Distributor O-ring	DTHTG10A-1-DO	1
10	Cylindre / Cylinder	DTHTG10A-1-L	1
11	Piston / Piston	DTHTG10AL-S-P	1
12	Cylindre extérieur / Case	DTHTG10AL-S-C	1
13	Anneau de retenue du piston / Stop Ring	DTHTG10A-1-S	1
14	Demies coquilles / Bit Retainer Ring	DTHTG10A-S-R	1
15	Joint torique demies coquilles / Bit Retainer Ring O Ring	DTHTG10A-S-RO	1
16	Roulement / Bearing	DTHTG10A-S-B	1
17	Entretoise tête et porte outil / Drive Chuck Washer	DTHTG10A-1-W	1
18	Porte outil / Drive Chuck	DTHTG10A-S-K	1

## Consommation d'air économique Economical Air Consumption

CFM m<sup>3</sup>/min

